

SIZE	NON-BLEED	BLEED* ————— (LIVE PRINT AREA)**
full page	7" x 10"	8.25" x 11" 8" x 10.75"
spread	15" x 10"	16.25" x 11" 16" x 10.75"
2/3 page	4.5625" x 10"	5.328" x 11" 5.078" x 10.75"
1/2 page vertical	3" x 10"	4" x 11" 3.75" x 10.75"
1/2 page island	4.5625" x 7.5"	5.243" x 8.137" 4.993" x 7.887"
1/2 page horizontal	7" x 4.875"	8.25" x 5.625" 8" x 5.375"
1/2 page junior spread	15" x 4.875"	16.25" x 5.491" 16" x 5.241"
1/3 page vertical	2.1875" x 10"	3.125" x 11" 2.875" x 10.75"
1/4 page	3.375" x 4.5"	N/A N/A

*Measurements include the additional .125" (each side) for proper bleed. **Live matter not intended to trim must be at least .25" from the edge

Contract Conditions

Rates subject to change upon notice. At the time a rate change is announced, a contract may be canceled without incurring a short-rate provided the contract rate has been earned up to the date of cancellation. Publisher reserves the right to hold advertisers and/or its advertising agency jointly and severally liable for such monies as are due and payable to the publisher.

A 15% discount will be paid to recognized advertising agencies upon payment of invoice. No discounts or commissions will be paid on invoices not paid within 60 days. If invoices are paid within 10 days, a 2% discount applies. An additional 3% will be added to invoices paid by credit card.

Neither the advertiser nor its agency may cancel (or make changes in) insertion orders after closing date. Cancellations or changes in insertion orders must be in writing, and are not considered accepted until confirmed in writing by publisher.

It is understood that the advertiser and/or agency will indemnify and hold the publisher harmless from and against any loss, expense, or other liability resulting from any claims or suits for libel, violation of rights of privacy, plagiarism, copyright infringement, or any other claims or suits that may arise out of the publication of such advertisement.

No contract will be accepted for a period longer than one year. Advance orders will be billed at the rates prevailing when the advertisement is published. No space cancellations will be accepted after closing dates. All special positions are accepted only on a non-cancelable basis.

Orders that earn volume discounts may be canceled by agencies upon written notice 30 days prior to closing date of the issue. Payment of account becomes due in full, including the difference between rates billed and rates earned on the space used. Advertisers will be short-rated to recover discounts forfeited because of unfulfilled contract.

Artwork converted at cost plus service charge, alterations made to printing materials at cost to be paid by advertiser.

Specialty Publishing Co., reserves the right to refuse advertising that is, in its estimation, not in keeping with the nature of Constructech's editorial mission.

ONLY Digital Files are Accepted

Include an identifying list for the files and creative contact information in the case of questions. Files must include crop marks that reflect the final trim size of the ad. If a bleed is desired, the graphic must extend .125" beyond the crop marks. We accept the following file formats for advertisements:

FULL PAGE ADs:

Press quality .PDF (only) with crop marks set at 8"(w) x 10.75"(h)

NON FULL PAGE ADs:

Hi resolution (300 dpi) .TIF, .EPS, or .PDF

We accept files on CD-ROM, DVD, or via email (files under 10 MB) For more information about setting up or emailing files, please contact lflakus@constructech.com.

Magazine Trim Size: 8" x 10.75"

Binding Method: Saddle-stitched

Proofs: You MUST provide a composite color proof at 100%. Proofs must contain crop and registration marks, and be submitted with the digital file. If a proof is not provided, SPC is not responsible if the print ad appears different than expected.

Shipping Instructions: Contracts, insertion orders, proofs, and instructions, all correspondence, and printing material (except preprinted inserts) should be sent to:

Constructech Magazine
 135 E. St. Charles Rd., Suite D
 Carol Stream, IL 60188
 P: +1 630.933.0844
 F: +1 630.933.0845
 Attn: Ad Traffic

Shipping labels should specify the issue in which advertisement is to be inserted. Please use fastest "traceable" carrier on all printing material.

Printing material stored by publisher for 12 months from issue date and then destroyed unless otherwise instructed in writing by advertiser and agency.

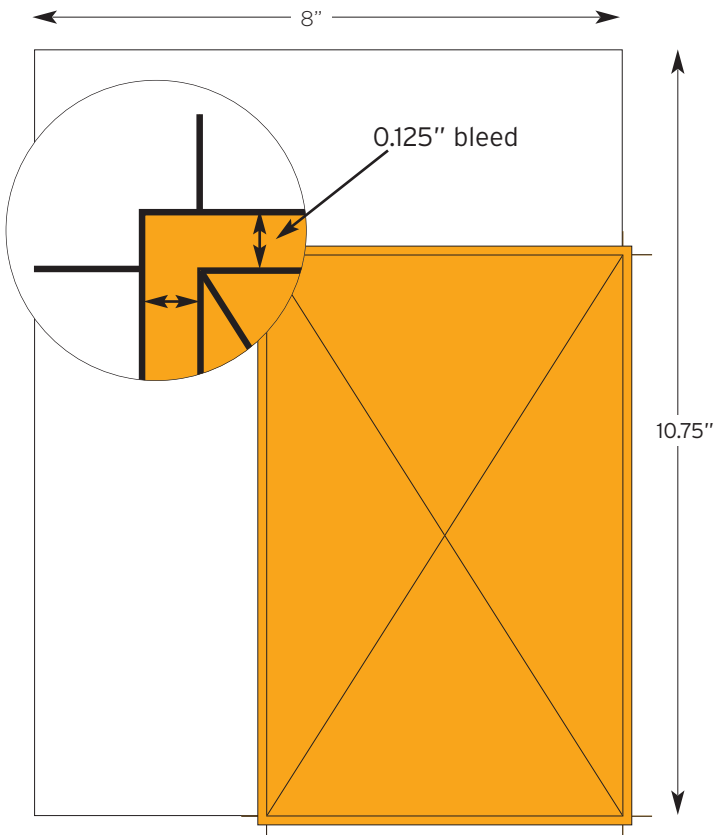

1/2 page island set-up bleed

CHECKLIST

Did you...

- Extend the graphic an additional .125" beyond the crop marks to allow for bleed.
- Keep all LIVE matter, not intended to trim, .25" from trim edge of live print area.
- Convert all RGB, Index, Lab, and Pantone colors to CMYK.
- Flatten and/or outline fonts before saving final file as an .EPS, .TIF, or .PDF in order to avoid font compatibility issues.
- Include crop and registration marks submitted with the digital file.
- Provide High resolution (300 dpi) .EPS, .TIF, or .PDF file formats. High quality .PDF (only) for full page ads.
- Include an indentifying list for the files and creative contact information in the case of questions.
- Provide a composite color proof at 100%.

NON-BLEED	BLEED
<p style="font-size: small;">4.5625" x 7.5"</p>	<p style="font-size: small;">5.243" x 8.137"</p>
1/2 page island	
<p style="font-size: small;">7" x 4.875"</p>	<p style="font-size: small;">8.25" x 5.625"</p>
1/2 page horizontal	

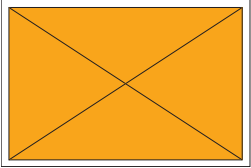
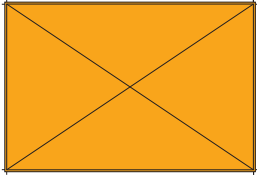
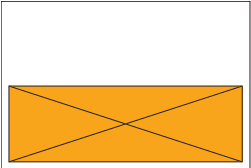
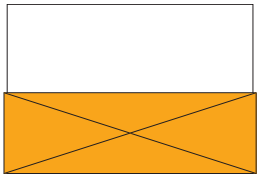
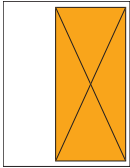
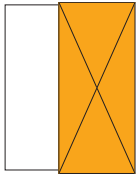
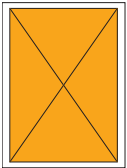
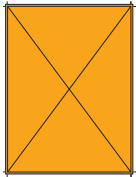
NON-BLEED	BLEED
	
15" x 10"	16.25" x 11"
Spread	
	
15" x 4.875"	16.25" x 5.491"
1/2 page junior spread	
	
4.5625" x 10"	5.328" x 11"
2/3 page	
	
7" x 10"	8.25" x 11"
Full page	

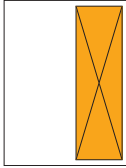
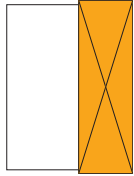
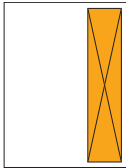
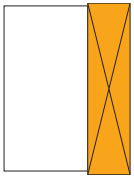
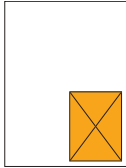
NON-BLEED	BLEED
	
3" x 10"	4" x 11"
1/2 page vertical	
	
2.1875" x 10"	3.125" x 11"
1/3 page vertical	
	N/A
3.375" x 4.5"	
1/4 page	

SHIPPING INSTRUCTIONS

All correspondence, contracts, insertion orders, proofs, and printing material (except preprinted inserts) should be sent to:

Constructech Magazine
135 E. St. Charles Rd., Suite D
Carol Stream, IL 60188
P: +1 630.933.0844
F: +1 630.933.0845
Attn: Ad Traffic